



SPECIFICATION

For

SWITCHING POWER SUPPLY

M/N: MPD-830V



Revision Index

REV.	092810	Updating the safety approval status.
REV.	032811	Updating the safety approval status.
REV.	010813	Updating the safety approval status.



1.0 INTRODUCTIONS

The MPD-830V is an off-line DC 48V input switching power supply is ideal for use in ATX personal computers, workstations, and equivalent systems. This power supply has designed to meet UL, CSA, and TUV safety approval.

2.0 INPUT SPECIFICATIONS

2.1 Input Voltage

The range of input voltage is from -40VDC to -72VDC.

2.2 Input current

The maximum input current is 10 at -48VDC input.

2.3 Inrush current

The inrush current will not exceed 10A at -48VDC input cold start, 25°C.

3.0 OUTPUT SPECIFICATIONS

3.1 The load range

	Output voltage	Min. load	Rated load	Max. load	Voltage accuracy
1	+5V	2A	25A	30A	4.80V to 5.20V
2	+12V	0.1A	10A	15A	11.40V to 12.60V
3	-12V	0A	1A	2A	-11.40V to -12.60V
4	-5V	0A	1A	2A	-4.75V to -5.25V
5	+3.3V	0A	8.0A	15A	3.13V to 3.4V
6	+5Vsb	0A	0.72A	1.2A	4.75V to 5.25V

At factory, all outputs in 60% rated load condition; the +5V output is set to between 4.80V and 5.20V. The other outputs are checked to be within the specified voltage accuracy range.

3.2 Output power

The total DC continuous power shall be kept within 300W ambient temperature of 40°C below, and input voltage at -48VDC.

The maximum, total combined output power on the 3V3 and 5V rails is 150W.

3.3 Ripple & Noise

The peak to peak ripple and noise for +5V, +3.3V outputs are less than 50mV, and for the other output are less than 100mV at rated load. Measuring is done by 15MHz bandwidth limited oscilloscope and terminated each output with a 0.47 μ F capacitor.

3.4 Line regulation

The output line regulation for each output is less than +-1% while measuring at rated load and -40V to -72VDC input voltage changing.

3.5 Load regulation

The output voltage load regulation is less than the values in the following table by changing



each output load $\pm 40\%$ from 60% from rated load, and keep other outputs at 60% rated load.

Output	#1	$\pm 3\%$	#3	$\pm 2\%$	#5	$\pm 2\%$
	#2	$\pm 5\%$	#4	$\pm 2\%$	#6	$\pm 3\%$

4.0 GENERAL FEATURES

4.1 Efficiency

The efficiency is higher than 65% while measuring at nominal line and rated output.

4.2 Protection

4.2.1 Over voltage protection

For some reasons the power supply might fail to control itself, the build-in crowbar circuit will automatically shut down the outputs to avoid damaging the external circuits. The trip point of O.V.P. circuit is around 5.7V to 7.0V.

4.2.2 Short circuit protection

The power supply will go into hiccup mode function against short circuit or over load conditions. If the faults condition removed, the power supply will restart automatically.

4.3 Power good signal

When power start-up, the power good signal will increase between 100ms to 500ms after all output DC voltages are within regulation limits.

4.4 Power fail signal

The power fail signal will fall at least 1ms before any of the output voltages lower than the regulation limits.

4.5 Power ON signal

This TTL compatible signal (active low) is use to switch ON the main output. When Power on is disconnected from secondary common, all outputs except +5Vsb shall turn off.

5.0 ENVIRONMENT SPECIFICATIONS

5.1 Operating temperature

0°C to 70°C (-20°C can start up)

When the ambient temperature is over 40°C (-48VDC) the output power should be derated as following curve.

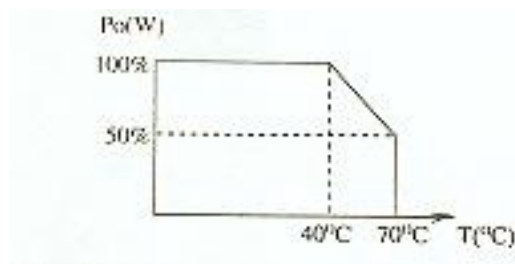



5.2 Storage temperature

-40°C to +75°C

5.3 Operating humidity

The power supply can operate from 5% humidity to 95% humidity non-condensing at 40°C

5.4 Altitude

Will operate properly at any altitude between 0 to 10000ft.

6.0 INTERNATIONAL STANDARDS

6.1 Safety standards

Designed to meet the following standards:

UL 60950-1, 2 nd Edition	UL approved
CAN/CSA C22.2 No. 60905-1-07	cUL approved
EN 60950-1, 2 nd edition	CE (LVD) declaration

6.2 EMI standards

Designed to meet the following radiated limits:

FCC	class "B"
EN 55022	class "B"

6.3 EMS standards

Designed to meet the following standards:

- IEC-801-2 8KV air discharge
- IEC-801-3 3V/M
- IEC-801-4 2KV
- IEC-801-5 2KV



7.0 MECHANICAL SPECIFICATION

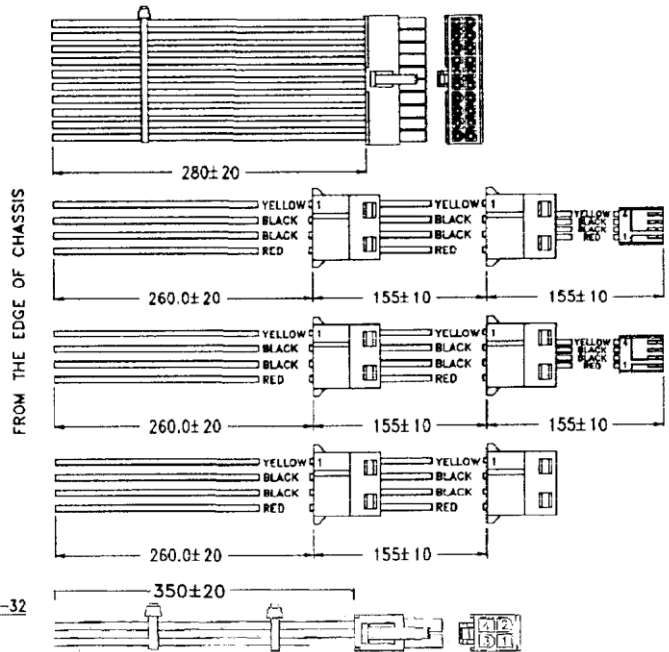
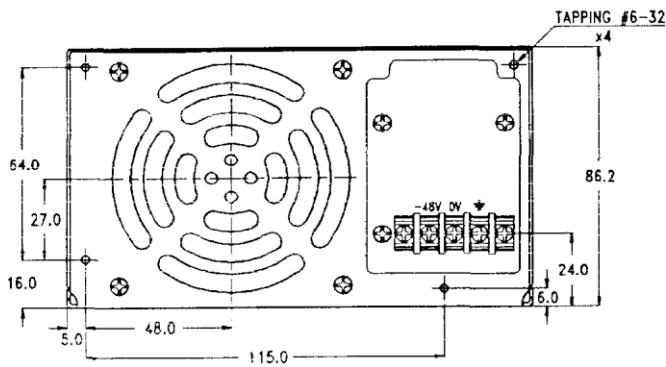
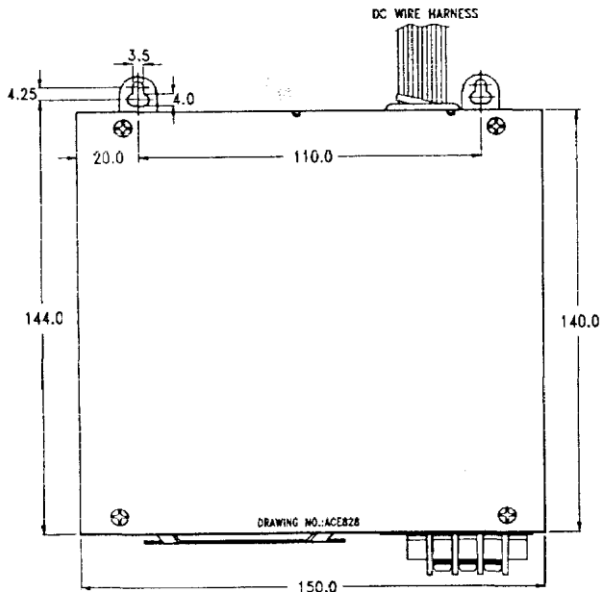

Wire Color	VOLTAGE
ORANGE	3.3V
RED	5V
YELLOW	12V
BLUE	-12V
GREY	P.G
WHITE	-5V
BLACK	GND
PURPLE	+5Vsb
GREEN	POWER ON

7.1 Dimensions

Dimensions are shown in mm as above.

Tolerance specified is +/-0.4mm between mounting holes, +/-0.8mm for other dimensions.

7.2 DC Connectors

3 positions terminal blocks

7.3 DC connectors

- ATX : Molex 39-01-2200 or equivalent.
- Disk drive : AMP 1-480424-0 or equivalent.
- 3 1/2" floppy driver : AMP 171822-4 or equivalent.
- P4 : Molex 39-01-2045 or equivalent.